



### MODEL SM81 UNIDIRECTIONAL CONDENSER MICROPHONE

The Shure Model SM81 is a high-quality, unidirectional condenser microphone designed for studio recording, broadcasting, and sound reinforcement. Its wide frequency response, low noise characteristics, and low RF susceptibility have made it a standard for applications involving acoustic instruments, especially guitar, piano, and cymbals.

The SM81 is ruggedly constructed. It operates on phantom power and performs over a wide range of temperatures and humidity conditions. It is furnished with a swivel adapter, attenuator-switch lock, foam windscreen, and case for carrying and storage. Other accessories are available.

#### Model SM81 Features

- 20 Hz to 20 kHz frequency response
- Flat response curve for accurate reproduction of sound sources
- Low noise and high output clipping level
- Low distortion over a wide range of load impedances
- Cardioid polar pattern, uniform with frequency and symmetric about axis, providing maximum rejection and minimum coloration of off-axis sounds
- Low RF susceptibility
- Selectable low-frequency response: flat, 6 or 18 dB/octave rolloff
- 0 dB/10 dB lockable attenuator switch
- Phantom powering (DIN 45 596 voltages of 12 to 48 Vdc)
- Rugged steel construction for durability
- Field-usable over wide range of temperature and humidity conditions

### SPECIFICATIONS

#### Type

Condenser (electret bias)

#### Frequency Response

20 to 20,000 Hz

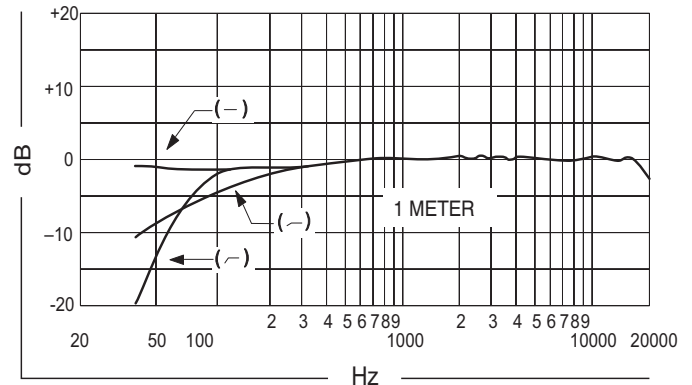

TYPICAL FREQUENCY RESPONSE

FIGURE 1

#### Polar Pattern

Cardioid (unidirectional) response-uniform with frequency, symmetrical about axis

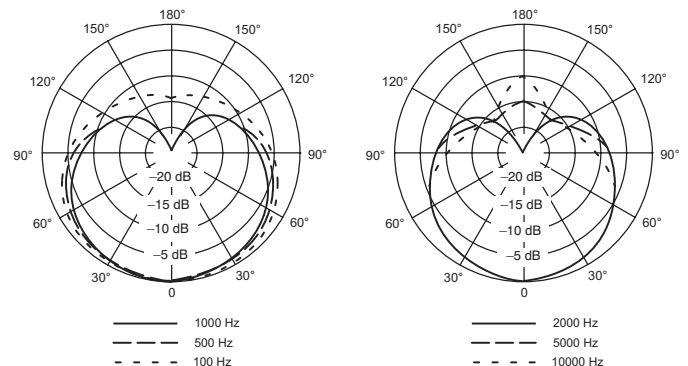

TYPICAL POLAR PATTERNS

FIGURE 2

#### Output Impedance

Rated at 150  $\Omega$  (85  $\Omega$  actual)

Recommended minimum load impedance: 800  $\Omega$  (May be used with loads as low as 150  $\Omega$  with reduced clipping level)

#### Output Configuration and Connector

Balanced, transformer-coupled output; male XLR connector

#### Sensitivity (at 1,000 Hz)

Open Circuit Voltage: . . . . . -45 dBV/Pascal (5.6 mV)  
(1 Pascal = 94 dB SPL)

#### Clipping Level (at 1,000 Hz)

800  $\Omega$  Load: . . . . . -4 dBV (0.63 V)  
150  $\Omega$  Load: . . . . . -15 dBV (0.18 V)

#### Total Harmonic Distortion

Less than 0.5% (131 dB SPL at 250 Hz into 800  $\Omega$  load)

**Maximum SPL (at 1,000 Hz)**

800 Ω load: .....	136 dB (attenuator at 0)
	146 dB (attenuator at -10)
150 Ω load: .....	128 dB (attenuator at 0)
	138 dB (attenuator at -10)

**Hum Pickup**

-3 dB equivalent SPL in a 1 mOe field (60 Hz)

**Self-Noise** (equivalent sound pressure levels; measured with true rms voltmeter)

16 dB typical, A-weighted  
19 dB typical, weighted per DIN 45 405

**Signal-to-Noise Ratio**

78 dB (IEC 651)\* at 94 dB SPL  
\*S/N ratio is difference between microphone output at 94 dB SPL and microphone self-noise A-weighted.

**Overvoltage and Reverse Polarity Protection**

Max. external voltage applied to pins 2 and 3 with respect to pin 1: ..... +52 Vdc  
Reverse polarity protection: ..... 200 mA max. (diode-clamped)

**Polarity**

Positive pressure on diaphragm produces positive voltage on pin 2 relative to pin 3

**Cartridge Capacitance**

54 pF

**Low Frequency Response Switch Positions**

Flat; -6 dB/octave below 100 Hz; -18 dB/octave below 80 Hz

**Attenuator Switch Positions (Lockable)**

0 or -10 dB

**Power**

Supply Voltage: ..... 11 to 52 Vdc, positive, pins 2 and 3  
Current Drain: ..... 1.2 mA max.

**Environmental Conditions**

Temperature

Storage: ..... -29° to 74° C (-20° to 165° F)  
Operating: ..... -6.7° to 49° C (20° to 120° F)

Humidity

Storage: ..... 0-95% relative humidity at room temperature (72° to 80° F, 22° to 27° C)

**Case**

Steel construction with vinyl metallic paint finish and stainless steel screens

**Dimensions**

See Figure 3

**Weight**

Net: ..... 230 grams (8 oz)  
Packaged: ..... 740 grams (1 lb 10 oz)

**Certification**

Eligible to bear CE marking. Conforms to European EMC Directive 89/336/EEC. Meets applicable tests and performance criteria in European EMC Standard EN 55103 (1996) parts 1 and 2 for residential (E1) and light industrial (E2) environments.

**OPERATION**

**Power**

The SM81 requires phantom power. This may be supplied to the microphone by a mixer, preamplifier or console with built-in phantom power or from an external power supply (such as the Shure model PS1A). Phantom power sources providing between 11 and 52 Vdc are suitable.

Use only high-quality cables because intermittent shorts between broken shield wires and balanced conductors will cause extremely large noise transients in the system. Avoid ground loops due to grounded connector shells or the microphone case touching other grounded metal objects. Follow generally accepted audio grounding practices.

**Impedance**

A minimum load impedance of 800 Ω or greater should be used for maximum signal handling and minimum distortion. The load may be as low as 150 Ω, but a reduction in output clipping level will result. It should be noted that the power supply itself may add loading (3300 Ω in the Shure PS1A power supply) to the microphones.

**PS1A Power Supply**

When using the Shure PS1A to phantom power the SM81, connect the microphone cable to the SM81 and to the MICROPHONE connector of the power supply. The power supply uses the balanced audio cable pair to carry the supply current to the microphone and the cable shield as a ground return.

Connect the OUTPUT connector of the power supply to a low-impedance microphone input of a mixer, audio console or tape recorder. A second SM81 may be connected to the remaining power supply channel in a similar manner.

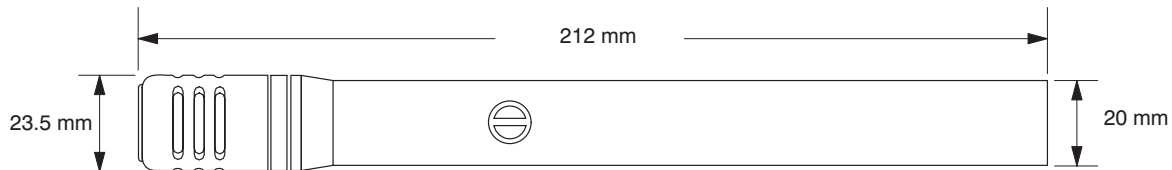

OVERALL DIMENSIONS  
FIGURE 3

## Low-Frequency Response Filter

The SM81 has a three-position low-frequency response filter controlled by a switch located on its handle. The switch is recessed to avoid accidental movement, but may be easily moved with fingertips. The user may select either flat response, low-frequency rolloff of 6 dB per octave below 100 Hz, or low-frequency cutoff of 18 dB per octave below 80 Hz (see Figure 4). When close-miking instruments or vocalists, an increase in low-frequency response (proximity effect) takes place. Figure 4 illustrates this effect with the switch in each of the three positions. Note that the low-frequency response filter may be used to compensate for proximity effect or reduce low-frequency noise from stage traffic and other sources.

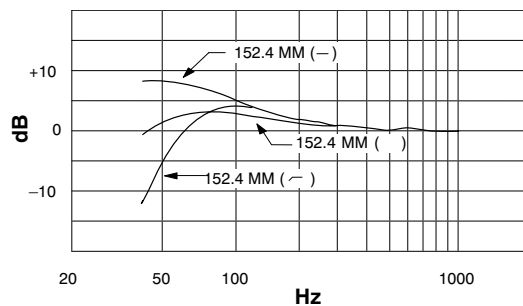

PROXIMITY EFFECT AND COMPENSATION  
FIGURE 4

## Attenuator Switch

The SM81 has a switchable 10 dB capacitive attenuator to prevent high sound pressure levels from overloading its internal electronics. The attenuator is engaged by rotating the actuator ring, located directly below the grille assembly, until it reaches the “-10” position. This reduces the output of the microphone by 10 dB and increases the maximum sound pressure level at clipping by 10 dB. There are no intermediate levels of attenuation available.

The attenuator ring may be locked in either the “0” or “-10” position as follows. Unscrew the grille and cartridge assembly by unscrewing counter-clockwise from the top. Turn the actuator ring to the “0” or “-10” position as desired. Insert the actuator ring lock (small clear piece of plastic) in the area behind the actuator ring between the pin and the edge of the slot. This will prevent the ring from turning. Replace the grill and cartridge assembly.

## Mixer Overload

The SM81’s output is about 15 dB higher than most dynamic microphones. At moderate to high SPLs, this additional output may

require attenuation (or padding). If no attenuation is available on the preamplifier, mixer or console being used, a resistive attenuator can be inserted between the microphone and the input. The Shure Model A15AS Attenuator (15, 20, or 25 dB switch-selectable) is specially designed for use with condenser microphones such as the SM81. Alternately, the attenuator design shown in Figure 5 may be used. The resistors shown are 1/2-watt, 1% tolerance, and the circuit may be packaged in a Switchcraft S3FM adapter housing. The circuit will provide 15 dB of attenuation and can be used between the SM81 and the PS1A (or other power supply), or between the PS1A and the mixer. Two of these circuits may be used in series to provide 30 dB of attenuation. (Note that, due to excessive loading, commercially available 150 Ω attenuators, such as the Shure Model A15AS, are not recommended when two are used in series.)

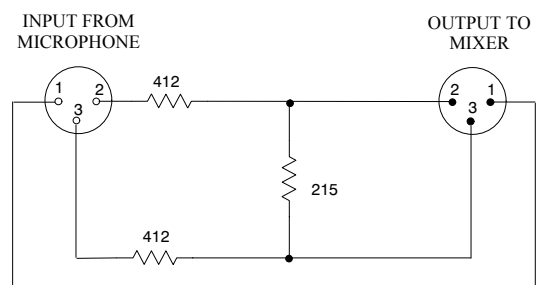

15 DB ATTENUATOR CIRCUIT  
FIGURE 5

## Wind Noise

The wide frequency response of the SM81 makes it sensitive to wind, breath, and air currents from heating, ventilation and cooling (HVAC) systems. The foam windscreens included with the SM81 can be used to reduce wind and breath noise, while the low-frequency response filter can be used to reduce low-frequency room noise caused by HVAC systems.

The Model A81G Pop Filter Grille attenuates breath popping sounds when the microphone is close-talked, and permits its use outdoors with minimal pickup of rushing and rumbling sounds. To install the A81G, slip it over the SM81 until the inside of the A81G touches the top of the microphone. Tighten the A81G by rotating the knurled collar clockwise from the bottom. (Note: When removing the A81G, first loosen the knurled collar. Otherwise the cartridge will unscrew with the A81G.)

For outdoor use under very windy conditions, use the Model A81WS large foam windscreen.

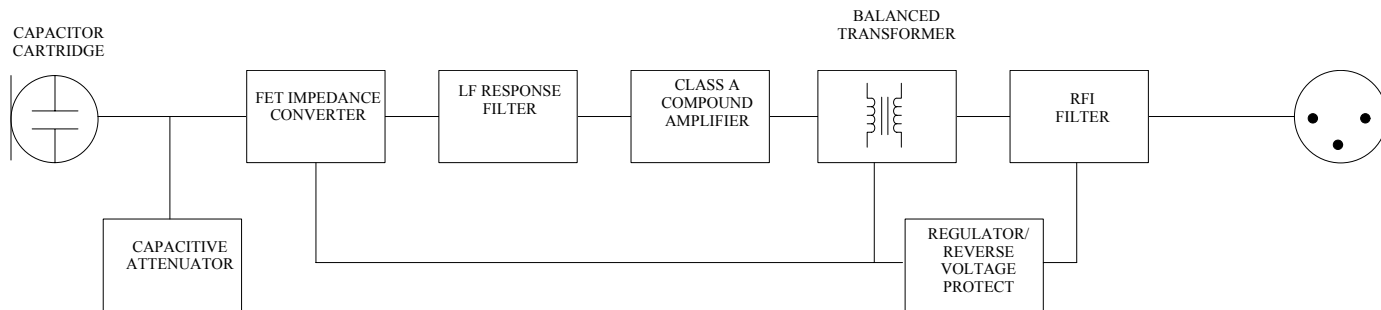

BLOCK DIAGRAM  
FIGURE 6

## CIRCUIT DESCRIPTION

A block diagram of the SM81 is shown in Figure 6. The capacitor cartridge is followed by a switch-controlled capacitive attenuator stage which provides for 10 dB attenuation at the cartridge output. The signal is fed to a field-effect transistor (FET) impedance conversion stage. The FET output drives an active low-frequency response (high-pass) filter controlled by a three-position switch. The filter output from a compound transistor, Class A, emitter-follower amplifier is transformer-coupled, providing a balanced output to the RFI protection filter at the microphone connector. An active, constant-current power supply circuit regulates the phantom voltage, allowing the SM81 to operate over a very wide range of voltages. A reverse voltage protection diode guards against miswired cables and equipment.

## TROUBLESHOOTING

If the SM81 fails to operate properly, verify that the microphone is powered properly.

1. Check the power supply output voltage to the microphone. For the Shure PS1A, this should be  $21.5 \pm 1.5$  Vdc open circuit.
2. Check the voltage on microphone connector pins 2 and 3 (at back of connector; cable connector disassembled from shell but connected to microphone). The voltage at pins 2 and 3 with reference to pin 1 should be between 11 and 52 Vdc.

Due to its high packing density and circuit complexity, disassembly of the SM81 is not recommended. Contact Shure's Service Department if problems persist.

## ARCHITECTS' SPECIFICATION

The microphone shall be a condenser microphone with a frequency response of 20 to 20,000 Hz. It shall have a unidirectional

pickup characteristic, with cancellation at the sides of 6 dB and a minimum cancellation at the rear of 15 dB at 1 kHz. The microphone shall have a rated output impedance of  $150 \Omega$  for connection to microphone inputs of 150 ohms or higher. The open circuit voltage shall be -65 dB (0.56 mV) (0 dB equals 1 volt per microbar).

The microphone shall contain a three-position low-frequency response switch and a lockable 10 dB attenuator pad.

The overall dimensions shall be 212 mm (8-11/32 in.) in length by 23.5 mm (15/16 in.) in diameter. The handle diameter shall be 20.1 mm (25/32 in.). The weight shall be 230 grams (8oz).

The microphone shall be capable of being powered by a phantom power supply with an output of 11 to 52 Vdc, or by a mixer, audio console or tape recorder capable of supplying 11 to 52 Vdc.

The microphone shall be a Shure Model SM81.

## FURNISHED ACCESSORIES

Swivel Adapter .....	A57F
10 dB Attenuator Lock .....	34A830
Carrying/Storage Case .....	65A1797
Windscreen .....	49A111

## OPTIONAL ACCESSORIES

Pop-Filter Grille .....	A81G
Heavy-Duty Windscreen .....	A81WS
Tripod Microphone Stand (4.3 m [14 ft]).....	S15A
Stereo Microphone Adapter .....	A27M
Cable (7.6m [25ft]) .....	C25F
Phantom Power Supply .....	PS1A

## REPLACEMENT PARTS

Cartridge and Grille Assembly .....	R104
-------------------------------------	------